

SPECIFICATIONS FOR LCD MODULE

CUSTOMER	
MODEL	SCT040001-V02
CUSTOMER APPROVED	

APPROVED BY	CHECKED BY	ORGANIZED BY
	Lr.Yin	Wf.Luo

ADD : 6F. B block of 10 Building Huafeng Technology Park. Fengtang Road

Fuyong town Baoan district Shenzhen Guangdong

TEL : 0755-81452160

FAX : 0755-81452166



0158

RECORDS OF REVISIONS

Revision No	Revision Date	Description
Ver: A0	2016-03-29	First release

CONTENTS

- General Description
- Interface Timing
- Electrical Characteristics
- Optical characteristics
- Reliability
- Precaution
- Outline Dimension
- Packing method

1. General Description

This LCM [SCT040001-V02](#) is a [IPS](#) LCD module, comprising a [1440](#)-channel source driver, a [32](#) Gate control signals, [480 \(RGB\) x 800](#) dots graphic, and power supply circuit. The 16M color can be display.

This TFT-LCD has [3.97](#) inch diagonally measured active display area with [WVGA](#) resolution.

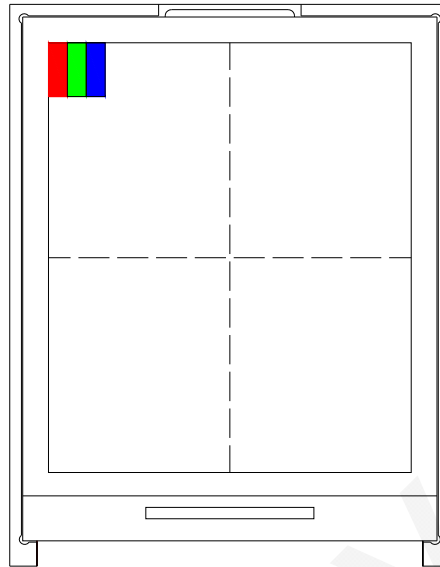

1.1 Mechanical Specifications

Item	Nominal Dimension	Unit
Dot Matrix	480 x RGB x 800	Dots
Module Size (W×H×T)	57.40 x 97.20 x 3.55	mm.
Active Area (W×H)	51.84 x 86.40	mm.
Pixel arrangement	RGB Stripe	mm.
Dot Pitch (W×H)	0.108 x 0.108	mm.
Color depth	16M	colors
Interface	MIPI DSI	-
Driving IC Package	COG	-

1.2 Display Specifications

Item	Nominal Dimension	Unit
Operating temperature	-20 ~70	°C
Storage temperature	-30~80	°C
LCD Type	IPS	-
LCD Mode	Normal Black	-
Backlight Type	LED x 8	PCS

1.3 Block Diagram

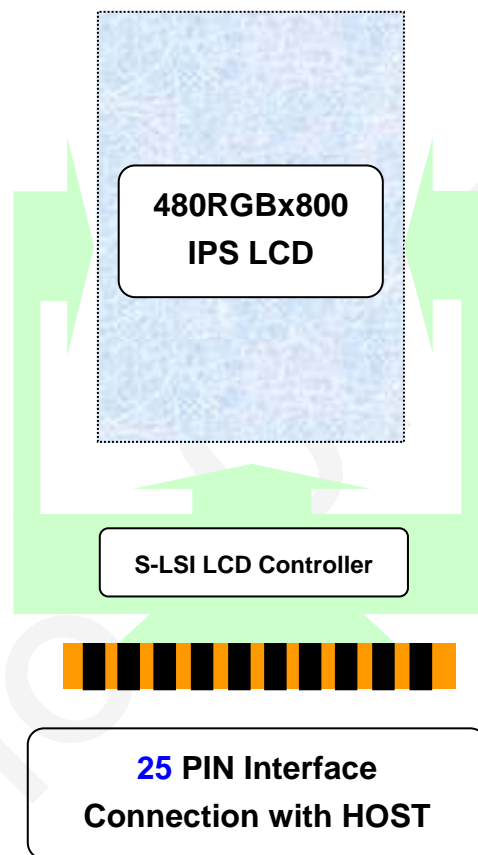

1.4 Back-light Unit

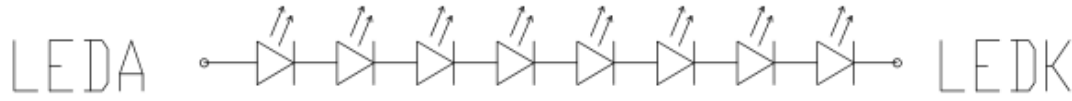

Item	Symbol	Condition	Min	Type	Max	Unit
Forward Voltage	V_f	Ta=25 °C, I _F =20mA	22	24.3	28	V
Forward Current	I_f	Ta=25 °C	-	20	20	mA
Luminance	vL	-	5000	-	-	cd / m ²
Uniformity	Avg	-	80	85	-	%
CIE	X	-	0.254	-	0.318	-
	Y	-	0.217	-	0.318	-
Power dissipation	P_d	-	-	512	-	mW
Backlight Driving Voltage	V_{AK}	-	22	24.3	28	V
LED lifetime	-	Ta=25 °C, I _F =20mA	20000			Hr
Drive method	Constant current					
LED Configuration	8 White LEDs in serial					

Note: The “LED lifetime” is defined as the module brightness decrease to 50% original brightness at Ta=25°C and IL =20mA. The LED lifetime could be decreased if operating IL is larger than 20mA.

1.5 Touch Panel Characteristics

1.Type: film+glass+tail

film: 亮面防牛

glass: 500 Ω / □ 普通 0.7mm

tail: FPC (pitch0.5)

2. Operating Voltage: ≤5V

3. Operation Temperature:-20° C~70° C

Storage Temperature:-30° C~80° C

4. Connect Material:FPC

5. Linearity: ≤1.5%

6. Response Time: ≤10ms

7. Transmittance: ≥80%

8. Surface Hardness ≥3H(Pencil)

9.operation force:<80g

10.Resistance:

(Double Layer ITO Film)x:100Ω~450Ω

(Stand ard ITO Glass)y:400Ω~1050Ω

11.Unspecified Tolerance:±0.20mm

1.6 Interface Pin

Pin No	Pin Symbol	Level	Description
1	LCM_ID	0V	LCM ID, have been connected to GND in FPC.
2	GND	0V	Ground
3	GND	0V	Ground
4	GND	0V	Ground
5	RESET	H/L	Reset signal
6	IOVCC	1.65-3.3V	Power supply for logic
7	GND	0V	Ground
8	HSSI_D0_N		These pins are DSI-D0+/- differential data signals if MIPI interface
9	NC		
10	HSSI_D0_P		
11	GND	0V	Ground
12	HSSI_CLK_N		These pins are DSI-CLK+/- differential clock signals if MIPI interface
13	NC		
14	HSSI_CLK_P		
15	GND	0V	Ground
16	HSSI_D1_N		These pins are DSI-D1+/- differential data signals if MIPI interface
17	NC		
18	HSSI_D1_P		
19	GND	0V	Ground
20	NC	-	No used
21	VCI	2.3-4.8V	Power supply
22	TE	H/L	Tearing effect output
23	LEDK	-	LED light, cathode.
24	LEDA	-	LED light, anode
25	GND	0V	Ground

Pin No	Pin Symbol	Level	Description
1	YU	-	Touch panel top
2	XL	-	Touch panel left
3	YD	-	Touch panel bottom
4	XR	-	Touch panel right

2. MIPI DSI Timing Characteristics

HIGH SPEED MODE

(VSS=VSSI=DVSS=0V, VDDI=1.65V to 3.3V, VDD=2.3V to 4.8V, Ta = -30 to 70 °C)

Signal	Symbol	Parameter	MIN	TYP	MAX	Unit	Description
DSI-CLK+/-	$2xU_{INST}$	Double UI instantaneous	4	-	25	ns	
DSI-CLK+/-	U_{INSTA} U_{INSTB}	UI instantaneous halves	2	-	12.5	ns	$UI = U_{INSTA} = U_{INSTB}$
DSI-Dn+/-	t_{DS}	Data to clock setup time	$0.15xUI$	-	-	ps	
DSI-Dn+/-	t_{DH}	Data to clock hold time	$0.15xUI$	-	-	ps	
DSI-CLK+/-	t_{DRTCLK}	Differential rise time for clock	150	-	$0.3xUI$	ps	
DSI-Dn+/-	$t_{DRTDATA}$	Differential rise time for data	150	-	$0.3xUI$	ps	
DSI-CLK+/-	t_{DFTCLK}	Differential fall time for clock	150	-	$0.3xUI$	ps	
DSI-Dn+/-	$t_{DFTDATA}$	Differential fall time for data	150	-	$0.3xUI$	ps	

Note) Dn = D0 and D1.



Fig. 7.6.4 DSI clock channel timing

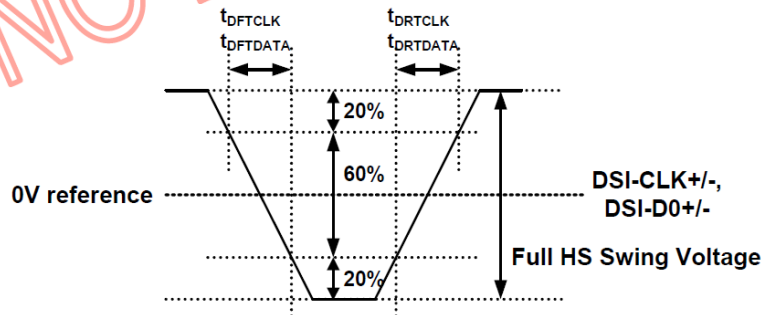

Fig. 7.6.5 Rising and fall time on clock and data channel

LOW POWER MODE

(VSS=VSSI=DVSS=0V, VDDI=1.65V to 3.3V, VDD=2.3V to 4.8V, Ta = -30 to 70 °C)

Signal	Symbol	Parameter	MIN	TYP	MAX	Unit	Description
DSI-D0+/-	T _{LPXM}	Length of LP-00, LP-01, LP-10 or LP-11 periods MPU → Display Module	50	-	75	ns	Input
DSI-D0+/-	T _{LPXD}	Length of LP-00, LP-01, LP-10 or LP-11 periods Display Module → MPU	50	-	75	ns	Output
DSI-D0+/-	T _{TA-SURED}	Time-out before the MPU start driving	T _{LPXD}	-	2xT _{LPXD}	ns	Output
DSI-D0+/-	T _{TA-GETD}	Time to drive LP-00 by display module	5xT _{LPXD}	-	-	ns	Input
DSI-D0+/-	T _{TA-GOD}	Time to drive LP-00 after turnaround request - MPU	4xT _{LPXD}	-	-	ns	Output

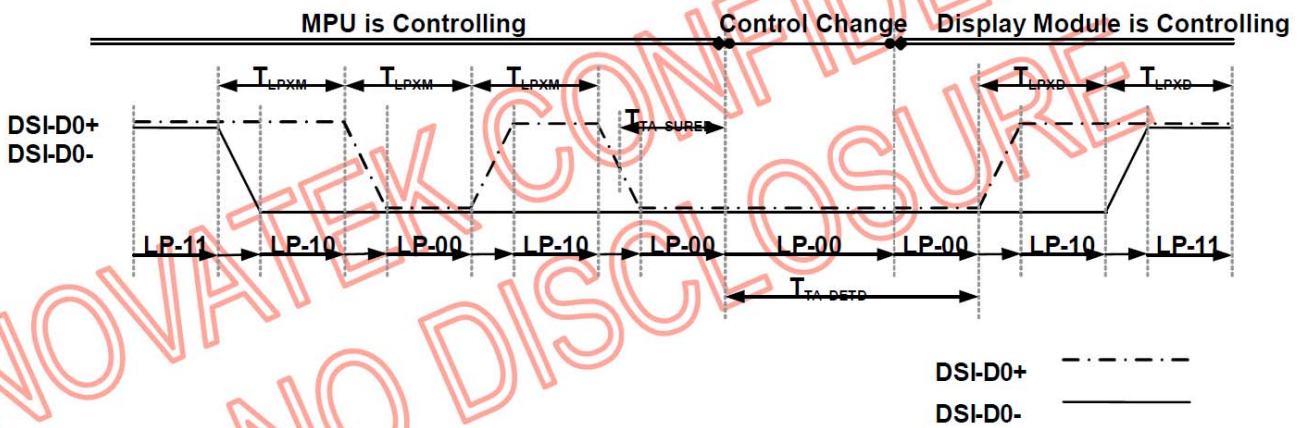

Fig. 7.6.6 Bus Turnaround (BAT) from MPU to display module Timing

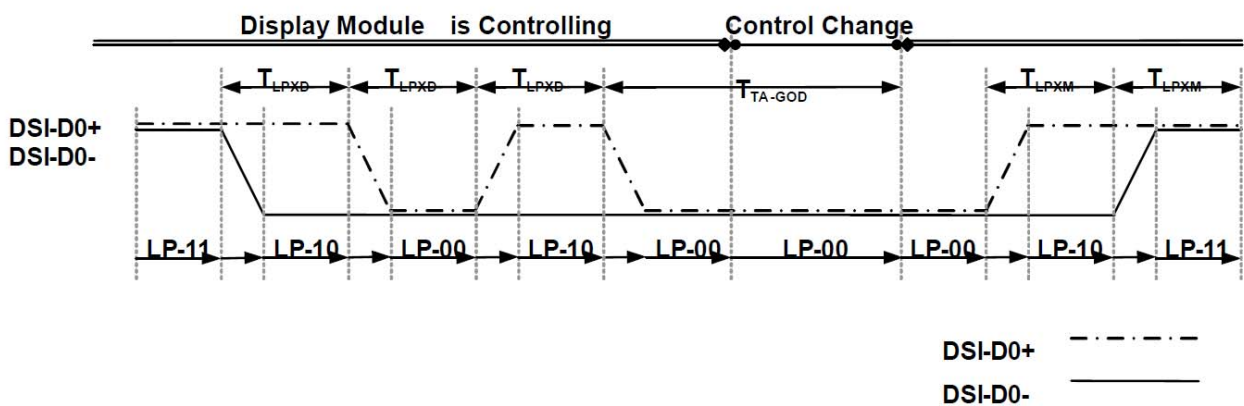

Fig. 7.6.7 Bus Turnaround (BAT) from display module to MPU Timing

DSI BURSTS

(VSS=VSSI=DVSS=0V, VDDI=1.65V to 3.3V, VDD=2.3V to 4.8V, Ta = -30 to 70°C)

Signal	Symbol	Parameter	MIN	TYP	MAX	Unit	Description
Low Power Mode to High Speed Mode Timing							
DSI-Dn+/-	T _{LPIX}	Length of any low power state period	50	-	-	ns	Input
DSI-Dn+/-	T _{HS-PREPARE}	Time to drive LP-00 to prepare for HS transmission	40+4xUI	-	85+6xUI	ns	Input
DSI-Dn+/-	T _{HS-TERM-EN}	Time to enable data receiver line termination measured from when Dn crosses V _{ILMAX}	-	-	35+4xUI	ns	Input
High Speed Mode to Low Power Mode Timing							
DSI-Dn+/-	T _{HS-SKIP}	Time-out at display module to ignore transition period of EoT	40	-	55+4xUI	ns	Input
DSI-Dn+/-	T _{HS-EXIT}	Time to drive LP-11 after HS burst	100	-	-	ns	Input
DSI-Dn+/-	T _{HS-TRAIL}	Time to drive flipped differential state after last payload data bit of a HS transmission burst	60+4xUI	-	-	ns	Input
High Speed Mode to/from Low Power Mode Timing							
DSI-CLK+/-	T _{CLK-POS}	Time that the MPU shall continue sending HS clock after the last associated data lane has transition to LP mode	60+128xUI	-	-	ns	Input
DSI-CLK+/-	T _{CLK-TRAIL}	Time to drive HS differential state after last payload clock bit of a HS transmission burst	60	-	-	ns	Input
DSI-CLK+/-	T _{HS-EXIT}	Time to drive LP-11 after HS burst	100	-	-	ns	Input
DSI-CLK+/-	T _{CLK-PREPARE}	Time to drive LP-00 to prepare for HS transmission	38	-	95	ns	Input
DSI-CLK+/-	T _{CLK-TERM-EN}	Time-out at clock lane display module to enable HS transmission	-	-	38	ns	Input
DSI-CLK+/-	T _{CLK-PREPARE} + T _{CLK-ZERO}	Minimum lead HS-0 drive period before starting clock	300	-	-	ns	Input
DSI-CLK+/-	T _{CLK-PRE}	Time that the HS clock shall be driven prior to any associated data lane beginning the transition from LP to HS mode	8xUI	-	-	ns	Input

Note) Dn = D0 and D1.

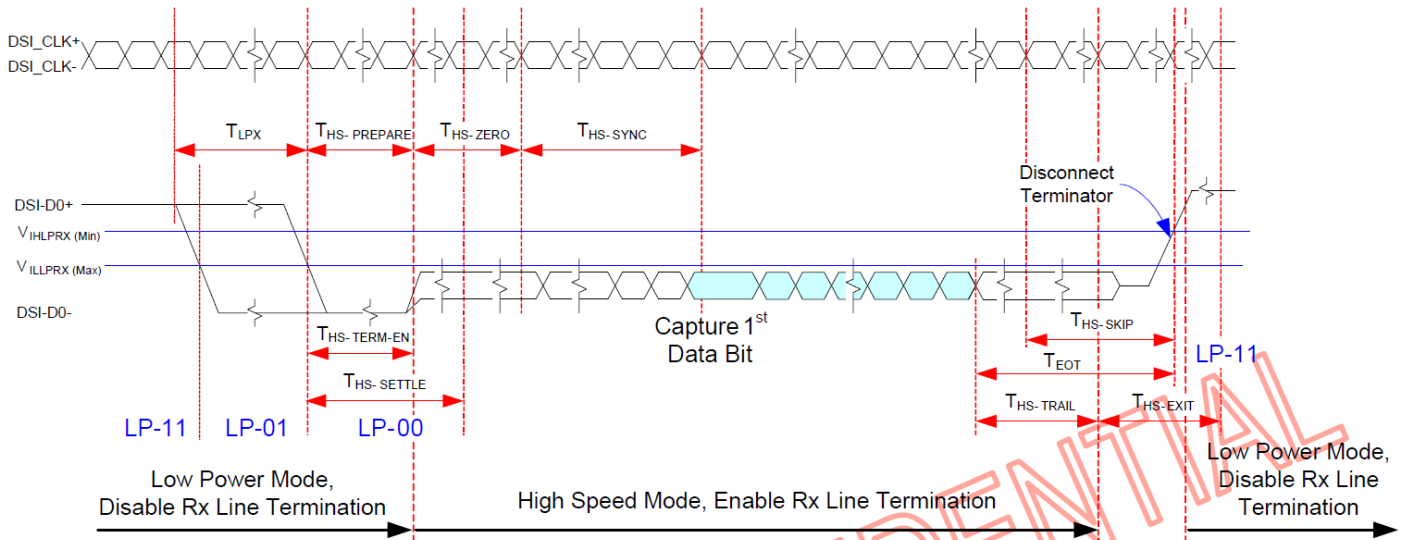

Fig. 7.6.8 Data lanes-Low Power Mode to/from High Speed Mode Timing

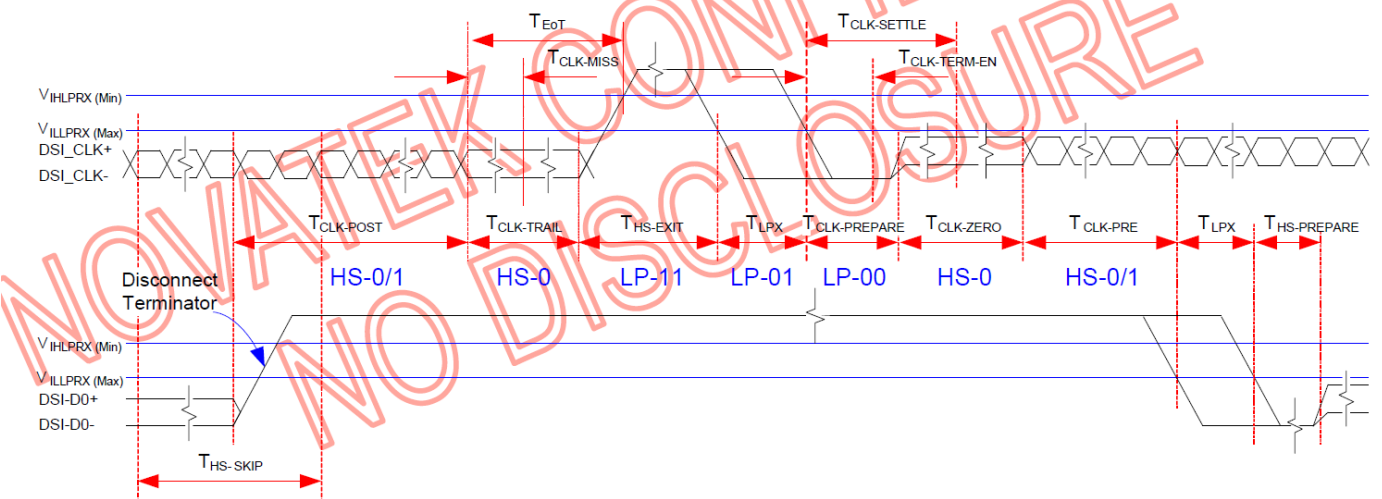

Fig. 7.6.9 Clock lanes- High Speed Mode to/from Low Power Mode Timing

3. Electrical Characteristics

3.1 Absolute Maximum Ratings

Item	Symbol	Min	Max	Unit
Supply voltage for System	VCI	0	+5.5	V
Supply voltage for Interface Operation	IOVCC	0	+5.5	V
Operate temperature range	TOP	-20	70	°C
Storage temperature range	TST	-30	80	°C

Note:

- (1) 90%RH maximum humidity, 60°C maximum wet-bulb temperature When operated at a temperature lower than 0°C, the LCD worked slowly and the screen appeared low-contrast images due to the characteristics of LC(Liquid Crystal).
- (2) If any fixed pattern is displayed on LCD for minutes, image-sticking phenomenon may occur.
- (3) Degradation could occur to pixels' TFT when DC BIOS is input into its gate-signal under POWER OFF WAITING STAND-BY & SLEEP MODE. Therefore, LCD should be turn off then.
- (4) Please operate a LCD module on the basis of the recommended S/W(Register)

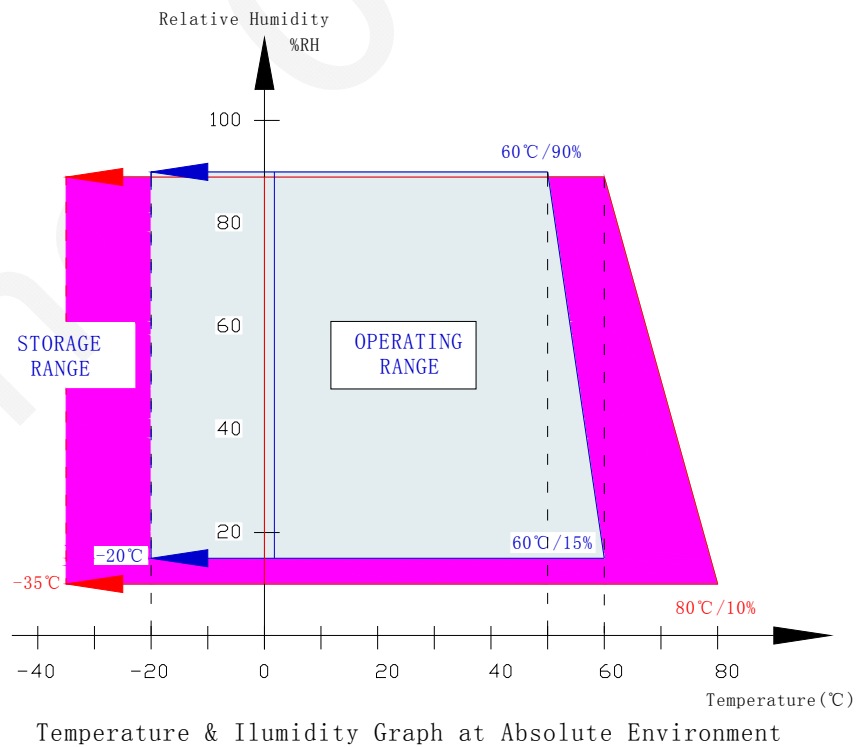

DATA). If you want to change any part of the S/W, you must take driver's confirmation.

3.2 DC Characteristics

$T_a = 25^\circ\text{C}$

Item	Symbol	Min	Typ	Max	Unit	Condition
Supply voltage for System	VCI	2.3	3.7	4.8	V	
Supply voltage for Interface Operation	IOVCC	1.65	1.8	3.3	V	
Input high level voltage	V_{IH}	0.7IOVCC	--	IOVCC	V	
Input low level voltage	V_{IL}	VSS	--	0.3IOVCC	V	
Power supply current	$I_{CC} + I_{CI}$	--	TBD	--	mA	
Backlight forward voltage	V_F	22	24.3	28	V	
Backlight forward current	I_F	--	20	20	mA	

4. Optical characteristics

Parameter		Symbol	Condition	Min	Typ	Max	Unit	Note
Viewing angle		Left	$CR \geq 10$		85		Degree	(2)
		Right			85		Degree	
		Up			85		Degree	
		Down			85		Degree	
Color Chromaticity	Red	Rx	$\theta = 0$ Normal viewing angle	0.615	0.665	0.715	-	Color Chromaticity
		Ry		0.273	0.323	0.373	-	
	Green	Gx		0.227	0.272	0.323	-	
		Gy		0.538	0.588	0.638	-	
	Blue	Bx		0.084	0.134	0.184	-	
		By		0.071	0.121	0.171	-	
	White	Wx		0.242	0.292	0.342	-	
		Wy		0.283	0.333	0.383	-	
Contrast ratio		CR	optimal	550	--		-	(1)
Response time		Tr+Tf			35		ms	(3)
Luminance on surface $I_f = 20\text{mA}$		Lv	Normally $\theta_x = \theta_y = 0$	250	280		cd/m^2	

Note (1) Definition of contrast ratio

Measured at the center point of panel

$$CR = \frac{\text{Luminance with all pixel white}}{\text{Luminance with all pixel black}}$$

Note (2) Definition of viewing angle

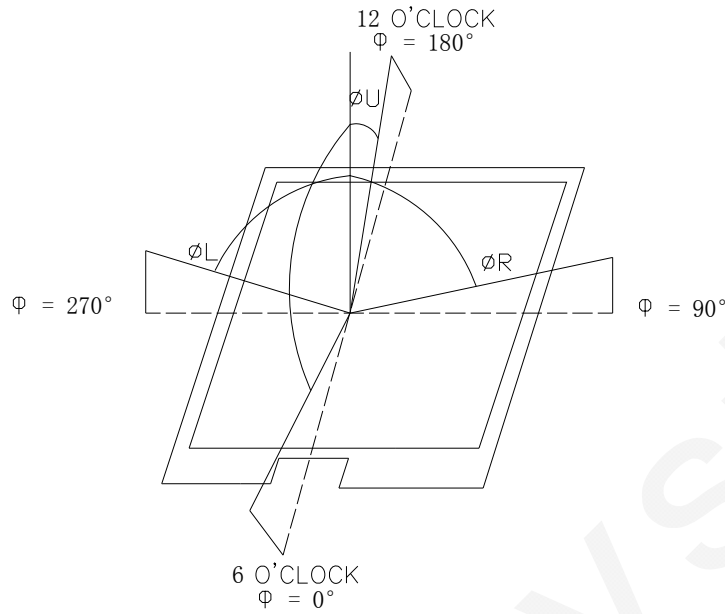

Note (3) Definition of response time: Tr+Tf

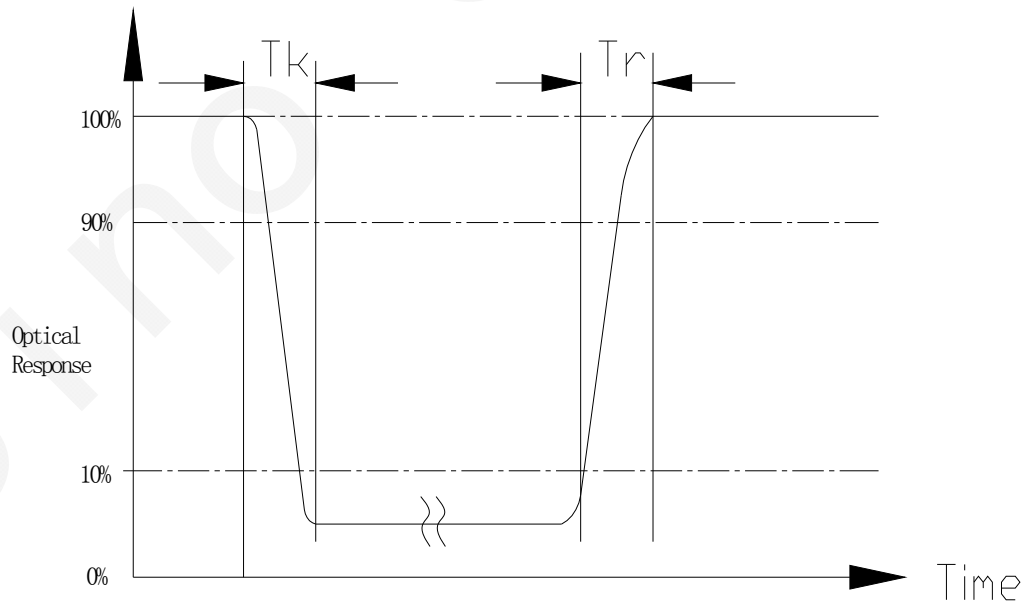

5. Reliability

5.1 Reliability Condition

Item No	Item	Condition	Remark
1	High temperature Operating	60°C, 120Hours	Finish product (With polarizer)
2	Low temperature Operating	-10°C, 120 Hours	Finish product (With polarizer)
3	High temperature Storage	70°C, 200 Hours	Finish product (With polarizer)
4	Low temperature Storage	-20°C, 200 Hours	Finish product (With polarizer)
5	High temperature & humidity Storage	50°C, 90%RH, 120 Hours	Finish product (With polarizer)
6	Thermal Shock Storage (No operation)	-10°C , 30min.<=> 60°C , 30min. 10 Cycles	Finish product (With polarizer)
7	ESD test	Voltage:±8KV R:330 ohm,C:150pF Air discharge,10 times	Finish product (With polarizer)
8	Vibration test	10 => 55 =>10 => 55 => 10 Hz, within 1 minute;Amplitude:1.5mm. 15 minutes for each Direction (X,Y,Z)	Finish product (With polarizer)
9	Drop test	Packed, 100CM free fall 6 sides, 1 corner, 3edges	Finish product (With polarizer)

*One single product test for only one item.

* Judgment after test: keep in room temperature for more than 2 hours.

- Current consumption < 2 times of initial value
- Contrast > 1/2 initial value
- Function: work normally

5.2 Inspection plan

Class	Item	Judgment	Class
Packing & Indicate	1.Outside and inside package	"Model no." , "lot no." and "quantity" Should indicate on the package.	Minor
	2.Model mixed and quantity	Other model mixed.....rejected. Quantity short or over....rejected.	Critical
	3.Product indication	"Model no." should indicate on the product	Major
Assembly	4.Dimension,LCD glass scratch And scribe defect	According to specification or drawing	Major
Appearance	5.Viewing area	Polarizer edge or LCD's sealing line is visible in the viewing arearejected	Minor
	6.Blemish 、 black spot 、 White spot in the LCD And LCD glass cracks	According to standard of visual inspection (inside viewing area)	Minor
	7. Blemish 、 black spot White spot and scratch on the polarizer	According to standard of visual inspection (inside viewing area)	Minor
	8.Bubble in polarizer	According to standard of visual inspection (inside viewing area)	Minor
	9.LCD's rainbow color	Strong deviation color (or Newton ring) of LCDrejected. Or according to limited sample (if needed, and inside viewing area)	Minor
	10.FPC	Burned area or wrong part number is on FPC. The symbol, character, and mark of FPC are unidentifiable. The stripped solder mask, A>1.0mm 0.3mm < stripped solder mask or visible circuit, A<1.0mm,and the number is ≧ 4 pieces. Particle between circuits in solder mask.. Circuit is peeled off or cracked. Any circuit risen or exposed. 0.2mm< Area of solder ball, A is ≧0.4mm,the number of solder ball is ≧ 3 pieces. The magnitude of solder ball, A is>0.4mm.	Minor

5.3 Standard of visual inspection

Class	Item	Judgment	Class
Electrical	11. Electrical and optical characteristics (contrast、VOP、chromaticity...etc)	According to specification or drawing. (inside viewing area)	Critical
	12. Missing pattern	Missing dot、line、character.....rejected	Critical
	13. Short circuit、wrong pattern display	Non display、wrong pattern display、current consumption out of specification.....rejected	Critical
	14. Pin hole、pattern deformity	According to standard of visual inspection	Minor
	15. Black spot、white spot、black line、white line、slant line、background uneven、color uneven	Strong deviation color.....rejected Or according to limited sample full off screen (all black) ...disregards	Minor
	16. Stick image (retention image)	Fixed test picture within two hours...rejected	Minor

Class	Item	Judgment																			
Minor	<ul style="list-style-type: none"> Blemish、black spot、white spot in the LCD. Blemish、black spot、white spot and scratch on th polarizer 	<p>(A) Round type: unit: mm</p> <table border="1"> <thead> <tr> <th>Diameter (mm.)</th> <th>Acceptable Q'ty</th> </tr> </thead> <tbody> <tr> <td>$0.2 < A$</td> <td>0</td> </tr> </tbody> </table> <p>Note: $A = (\text{Length} + \text{Width}) / 2$</p> <p>(B) Liner type: unit: mm</p> <table border="1"> <thead> <tr> <th>Length</th> <th>Width</th> <th>Acceptable Q'ty</th> </tr> </thead> <tbody> <tr> <td>---</td> <td>$W \leq 0.03$</td> <td>Disregard</td> </tr> <tr> <td>$L \leq 5$</td> <td>$0.03 < W \leq 0.05$</td> <td>3</td> </tr> <tr> <td>$L \leq 5$</td> <td>$0.05 < W \leq 0.07$</td> <td>1</td> </tr> <tr> <td>---</td> <td>$0.07 < W$</td> <td>Follow round type</td> </tr> </tbody> </table>	Diameter (mm.)	Acceptable Q'ty	$0.2 < A$	0	Length	Width	Acceptable Q'ty	---	$W \leq 0.03$	Disregard	$L \leq 5$	$0.03 < W \leq 0.05$	3	$L \leq 5$	$0.05 < W \leq 0.07$	1	---	$0.07 < W$	Follow round type
Diameter (mm.)	Acceptable Q'ty																				
$0.2 < A$	0																				
Length	Width	Acceptable Q'ty																			
---	$W \leq 0.03$	Disregard																			
$L \leq 5$	$0.03 < W \leq 0.05$	3																			
$L \leq 5$	$0.05 < W \leq 0.07$	1																			
---	$0.07 < W$	Follow round type																			
Minor	Bubble in polarizer	<p>unit: mm</p> <table border="1"> <thead> <tr> <th>Diameter</th> <th>Acceptable Q'ty</th> </tr> </thead> <tbody> <tr> <td>$A \leq 0.3$</td> <td>Disregard</td> </tr> <tr> <td>$0.3 < A \leq 0.5$</td> <td>1</td> </tr> <tr> <td>$0.5 < A$</td> <td>0</td> </tr> </tbody> </table>	Diameter	Acceptable Q'ty	$A \leq 0.3$	Disregard	$0.3 < A \leq 0.5$	1	$0.5 < A$	0											
Diameter	Acceptable Q'ty																				
$A \leq 0.3$	Disregard																				
$0.3 < A \leq 0.5$	1																				
$0.5 < A$	0																				
Minor	Pin hole、Pattern deformity	<p>unit: dot size</p> <table border="1"> <thead> <tr> <th>Diameter</th> <th>Acc. Q'ty</th> </tr> </thead> <tbody> <tr> <td>$0.4 < \Phi$</td> <td>0</td> </tr> </tbody> </table>	Diameter	Acc. Q'ty	$0.4 < \Phi$	0															
Diameter	Acc. Q'ty																				
$0.4 < \Phi$	0																				

6. Precaution

6.1 Handling

- (1) Protect the panel from static, it may cause damage to the CMOS Gate Array IC.
- (2) Use fingerstalls with soft gloves in order to keep display clean during the incoming inspection and assembly process.
- (3) If the liquid crystal material leaks from the panel, it should be kept away from the eyes or mouth. In case of contact with hands, legs or clothes, it must be washed away thoroughly with soap.
- (4) The desirable cleaners are water, IPA (Isopropyl Alcohol) or Hexane. Don't use Ketone type materials (ex. Acetone), Ethyl alcohol, Toluene, Ethyl acid or Methyl chloride. It might permanent damage to the polarizer due to chemical reaction.
- (5) Pins of I/F connector shall not be touched directly with bare hands.
- (6) Refrain from strong mechanical shock and / or any force to the panel. In addition to damage, this may cause improper operation or damage to the panel.
- (7) Note that polarizers are very fragile and could be easily damaged. Do not press or scratch the surface harder than a B pencil lead.
- (8) Wipe off water droplets or oil immediately. If you leave the droplets for a long time, staining and discoloration may occur.
- (9) If the surface of the polarizer is dirty, clean it using some absorbent cotton or soft cloth.

6.2 Storage

- (1) Do not leave the panel in high temperature, and high humidity for a long time. It is highly recommended to store the panel with temperature from 0 to 35°C and relative humidity of less than 70%.
- (2) The panel shall be stored in a dark place. It is prohibited to apply sunlight or fluorescent light during the store.

6.3 Operation

- (1) The LCD shall be operated within the limits specified. Operation at values outside of these limits may shorten life, and/or harm display images.
- (2) Do not exceed the absolute maximum rating value. (the supply voltage variation, Input voltage variation in part contents and environmental temperature and so on). Otherwise the panel may be damaged.
- (3) If the panel displays the same pattern continuously for a long period of time, it can be the situation when the image" Sticks" to the screen.

7. Outline Dimension

Refer to SCT040001-V02 drawing.

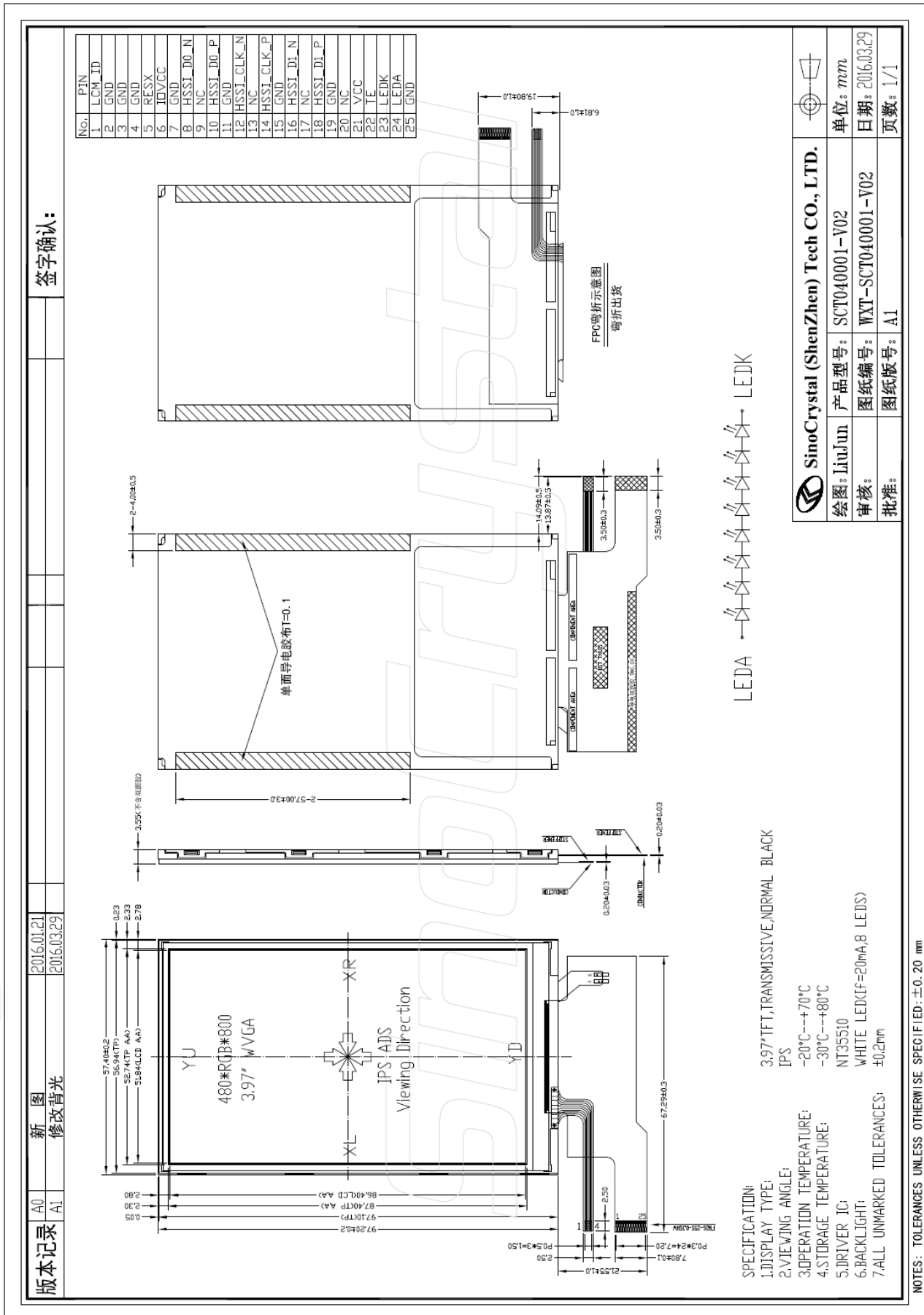

8. Packing method

8.1 Packing Quantity (TBD)

8.2 Flowing chart (TBD)

SinoCrystal